

Operating Instructions

Minilab

Model PVF-C



Accessories:

Transverse Strength Attachment
Twin-Transverse Shear Strength Attachment
Screening Device for Preparation Sample
Tensile Strength Device
High Pressure Measuring Device

Model

PBV/M
PQS/M
PES
PZV/M
PHD/M

Type:	Minilab
Model:	PVF-C
Part No.:	592-820-650
Serial No.:	

Name and address of manufacturer:

Simpson GmbH
Thomas-Eber-Str. 86
D - 53879 Euskirchen,
Germany

For other Simpson offices around the world and for our contact information please visit us on the internet at simpsongroup.com on the Contacts page.

This document is strictly confidential.

This document is protected under the copyright laws of the United States and other countries as an unpublished work. This document contains information that is proprietary and confidential to Simpson or its subsidiaries which shall not be disclosed outside or duplicated, used, or disclosed in whole or in part for any purpose other than to evaluate Simpson for a proposed transaction. Any use or disclosure in whole or in part of this information without the express written permission of Simpson is prohibited.

© 2025 SIMPSON a division of Norican Group North America, Inc

Table of Contents

4.1	Unpacking.....	21
4.2	Components	22
4.3	Installation	23
4.4	Electrical and Pneumatic Power Connection	24
4.5	Connecting Power and Set-Up	25
4.6	Airborne Noise Emission	26
5	Commissioning.....	27
5.1	Adjustments.....	27
5.1.1	Compressed Air Pressure	27
5.1.2	Power	28
5.2	Operating Component and Functions.....	28
5.2.1	Operator Panel (OP).....	28
5.3	Connecting External Devices.....	29
5.3.1	Personal Computer (PC)	29
5.3.2	Printer.....	30
6	Operating Instructions	31
6.1	Menu Outline.....	31
6.1.1	Measurements.....	31
6.1.2	Options.....	32
6.1.3	Measurement Series	40
6.2	Operation	41
6.2.1	Test Specimen Manufacture	41
6.2.2	Compactability Measurement.....	43
6.2.3	Compression Strength Measurement	44

6.2.4	Splitting Strength Measurement.....	46
6.2.5	Twin-Transverse Shear Strength Measurement (PQS/M).....	48
6.2.6	Transverse Strength Measurement (PBV/M)	51
6.2.7	Tensile Strength Measurement (PZV/M)	53
6.2.8	High Pressure Measurement (PHD/M).....	55
6.2.9	Wet Tensile Strength Measurement	57
7	Maintenance and Calibration	59
7.1	Daily Maintenance.....	59
7.2	Quarterly Maintenance (Every Three Months).....	60
7.3	Calibration	60
8	Apparatus Layout.....	63
9	Parts List / Ordering Parts / Returns	68
9.1	Spare Parts List	68
9.2	Ordering Replacement / Spare Parts.....	70
9.3	Return Goods Policy	70
10	Decommissioning.....	73

SIMPSON

A Norican Technology

This Page is Intentionally Blank

1 Introduction

Congratulations, you have just purchased an extremely reliable sand testing instrument that is backed by the professional technical support and years of proven sand technology experience of Simpson .

This laboratory equipment is constructed of quality materials and is the result of unsurpassed craftsmanship. The Minilab should be operated only when it is in perfect condition, in accordance with its designed purpose and while being aware of hazards. Observe the safety instructions in Section 2 and operating instructions in Section 6.

1.1 Application and Designated Use

This device is intended exclusively for producing a foundry sand sample or measuring the strength and compact ability of foundry sands mixed with chemical and clay binders. Usage of other materials may be possible upon consultation with the technical service of Simpson .

Any other application outside the intended usage will be regarded as use not in accordance with its purpose, and, therefore, the manufacturer/supplier will not be held liable for any damage that might arise hereunder. The risk in this case will be exclusively that of the user.

1.2 Organizational Measures

The operating instructions should be readily available at the place of operation. In addition to the operating instructions, the general legal regulations, or other mandatory rules for the prevention of accidents and environmental protection should be made known and observed!

The personnel instructed to use this apparatus, before beginning work, should have studied and fully understood these Operating Instructions, in particular the “Safety” chapter.

No modifications, extensions, or changes in design of the device that would impact safety requirements should be put into effect without prior consent from the supplier! Spare parts must conform to the technical specifications defined by the manufacturer. This is always guaranteed when using original spares.

2 Safety

NOTICE

Before operating and/or performing maintenance or repair on Simpson designed and/or manufactured equipment, it is required that all personnel have read and understood the entire Operation Maintenance manual. If any questions exist, you must contact your supervisor or Simpson before taking further action.

If properly operated and maintained, you are Simpson supplied equipment can provide many years of dependable and safe operation. Please follow all recommended safety, operating, and maintenance instructions. Furthermore, the introduction of any non-Simpson manufactured and/or approved parts to the equipment may create a hazardous situation. Never alter the equipment without prior consultation with Simpson .



DO NOT use this machine for purposes other than that for which it is intended. Improper use could result in death or severe injury.

2.1 Safety Signs and Labels

Simpson has incorporated the ANSI Z535.6/ISO 3864-1-2 safety symbol only label format on all of its laboratory equipment.

The harmonized ANSI Z535.6 format became an established safety label format since it not only fully meets the current ANSI Z535 standards but also incorporates ISO 3864-2 symbols and hazard severity panel and thus, can be used for both the U.S. and international markets.

2.1.1 Safety Alert Symbols



This is the safety alert symbol. It is used to alert you to potential personal injury hazards. OBEY all safety messages that follow this symbol to avoid injury or death.



DANGER! *Indicates an imminently hazardous situation which, if not avoided, will result in death or severe injury.*



The safety alert symbol used without a signal word to call attention to safety messages indicates a potentially hazardous situation which, if not avoided, could or may result in death or minor injury.



NOTICE *NOTICE indicates information used to address practices not related to personal injuries but may result in property damage.*



This symbol indicates information containing important instructions concerning the use of the machine or directions for further procedures. Ignoring this information can lead to the malfunction of the machine.

2.1.2 Safety Symbol Labels



NO CHANGE OR PART SUBSTITUTIONS

(STC #998-4725)

This label is located on the left side of the panel enclosure above the main switch.

No changes or part substitutions shall be made to this equipment without consulting Simpson. Changes may compromise safety features, resulting in a hazardous situation.



PINCH POINTS

(STC #998-4727)

This label is located on the Piston of the pneumatic cylinder.

With the service doors open, body parts may be **crushed** or **cut** between the Piston and Minilab Base Plate from both intentional and unintentional movement of the piston. Follow **Lockout and Tagout** procedures before servicing and always ensure Protection Doors are closed before testing.



AUTOMATED VERTICAL MOVEMENT

(STC #998-4728)

This label is located on the right service door next to the handle.

After power interruption, an automatic restart may occur. In this case, the piston will move upward. Follow **Lockout and Tagout** procedures before servicing.



ELECTRICAL POWER 230V

(STC #998-4732)

This label is located on the back side of the panel enclosure next to the power connection inlet.

With the socket outlet connection removed, the electrical power supply and electrical terminals are exposed. A hazardous voltage up to 230V is present, can cause electric shock or burn and will result in severe injury. Follow **Lockout and Tagout** procedures before servicing.



ELECTRICAL POWER

(STC #596-296-020)

This label is located inside the panel enclosure on the right side, above the manometer.

With the panel enclosure door open, the electrical power supply and electrical terminals are exposed. A hazardous voltage is present, can cause electric shock or burn and will result in severe injury. Follow **Lockout and Tagout** procedures before servicing.



READ AND UNDERSTAND ALL SERVICE MANUAL INSTRUCTIONS

(STC #998-4731)

This label is located on the left side of the panel enclosure above the main switch.

Before operating and/or performing any maintenance or repair on Simpson designed and/or manufactured equipment, it is required that all personnel read and understand the entire Operating Instructions manual. All protective guards and covers shall be installed and all doors closed before operating the equipment. If any questions remain unanswered, you must contact your supervisor or Simpson before taking further action. Follow **Lockout and Tagout** procedures before servicing.

2.2 Lockout and Tagout System Procedure

NOTICE

*Whenever performing any type of maintenance or repair, whether in the form of cleaning, inspection, adjustment, mechanical or electrical maintenance, the equipment must be rendered into **Zero Mechanical State (ZMS)**.*

Prior to maintenance (routine or otherwise) or repair of equipment, safety procedures should be established and maintained. This procedure should include training of all personnel involved with the equipment; identification and labeling of all equipment which is interlocked mechanically, electrically, through hydraulics, pneumatics, levers, gravity or otherwise; and a listing of the established lockout procedures posted on each piece of equipment.

“Lockout and Tagout” refers to specific practices and procedures to safeguard personnel from the unexpected energizing of machinery and equipment, or the release of hazardous energy during service or maintenance activities. This requires, in part, that a designated individual turns off and disconnects the machinery or equipment from its energy source(s) before performing service or maintenance, and that the authorized employee(s) lock or tag the energy-isolating device(s) to prevent the release of hazardous energy and take steps to verify that the energy has been isolated effectively.

2.2.1 Lockout and Tagout Devices

When attached to an energy-isolating device, both lockout and tagout devices are tools used to help protect personnel from hazardous energy. The lockout device provides protection by holding the energy-isolating device in a safe position, thus preventing the machine or equipment from becoming energized. The tagout device does so by identifying the energy-isolating device as a source of potential danger. It indicates that the energy-isolating device and the equipment being controlled may not be operated until the tagout device is removed.

2.2.2 Glossary

Authorized Person(s) - Personnel who have been designated by his/her department to perform maintenance or service on a piece or piece of equipment, machinery, or system. These individuals are qualified to perform the work through proper training on the Lockout/Tagout procedures for the equipment, machinery, or system.

Lockout - The placement of a Tagout device on an energy-isolating device, in accordance with an established procedure, to indicate that the energy isolating device and the equipment being controlled may not be operated until the Tagout device is removed.

Lockout Device - Any device that uses positive methods, such as a lock (either key or combination type), to hold an energy-isolating device in a safe position, thereby preventing the energizing of machinery or equipment. When professionally installed, a blank flange or bolted slip blind are considered equivalent to lockout devices.

Tagout - The placement of a Tagout device on an energy-isolating device, in accordance with an established procedure, to indicate that the energy isolating device and the equipment being controlled may not be operated until the Tagout device is removed.

Tagout Device - Any prominent warning device, such as a tag and a means of attachment, which can be securely fastened to an energy isolating device in accordance with an established procedure. The tag indicates that the machine or equipment to which it is attached is not to be operated until the Tagout device is removed in accordance with the energy control procedure.

Zero Mechanical State - The mechanical potential energy of all portions of the equipment or machine is set so that the opening of pipes, tubes or hoses, and the actuation of any valve, lever, or button, will not produce a movement which could cause injury.

3 Short Description & Specifications

3.1 Application

The Minilab, Model PVF-C, is a multi-purpose instrument used to determine strength properties of clay and/or chemically bonded foundry sand specimens. The instrument may be used to create a 50mm x 50mm cylindrical test specimen and determine several sand properties through various tests. (Note: the properties of Minilab sand specimens are different than those of rammed sand specimens. The compressive strengths of rammed and squeezed sand cannot be compared on a 1:1 basis.) A vertically moving piston applies pressure on a sand specimen until failure. The force data is then displayed on a digital operator panel on the front of the instrument.

3.2 Description

The Minilab, Model PVF-C, is capable of running many different sand strength tests with additional fixtures and accessories that are easy to connect to the instrument. These tests include green sand compactability, compression strength, splitting strength, twin-transverse shear strength, core transverse (bending) strength, and others.

After placing the sand specimen in the strength accessory, the operator selects the desired test and the piston places pressure on the sand specimen until it breaks. The digital display panel shows the strength value in N/cm² (various strength resolutions are specified by test on the following pages). The machine may be calibrated as necessary using spring forces and piston displacement. (See section 7.3)

3.3 Measurement Types

Compactability

Resolution: 0.1%

Test Specimen

Resolution: 0.1mm

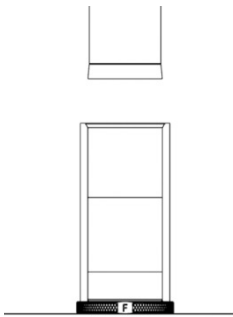

Compression Strength

Resolution: 0.1 N/cm²

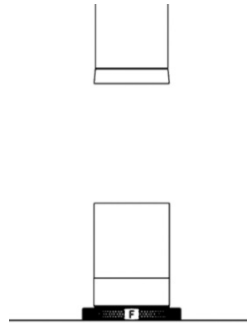

Splitting Strength

Resolution: 0.1 N/cm²

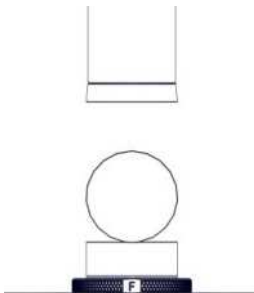

Twin-Transverse Shear Strength

Resolution: 0.1 N/cm²

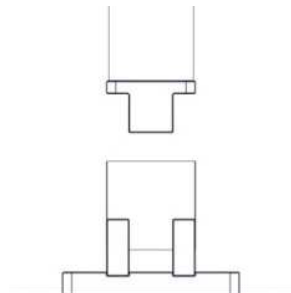

3 Short Description & Specifications

Transverse Strength

Resolution: 1 N/cm²

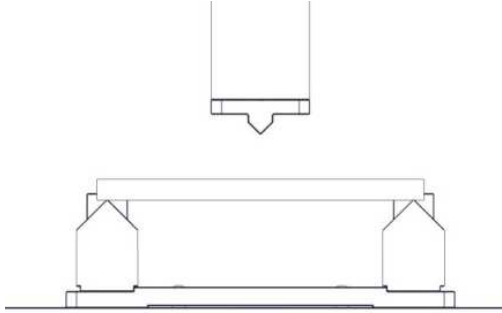

In addition to these standard test types, the following values may be recorded on the Minilab when the corresponding device is connected.

Value Type	Device	Resolution (N/cm ²)
Wet Tensile Strength	PNZ	0.001
Permeability	PED	1 unit
Tensile Strength	Test Tool	0.1
High Pressure	Test Tool	1

3.4 Specifications, Dimensions and Weights (Approximate)

Specifications	Minilab
Length	830 mm (32.6 in)
Width	400 mm (15.7 in)
Height	250 mm (9.8 in)
Weight	56 kg (123.4 lbs.)
Power	230 V - 50 Hz
Air Compressed	Min. 5 bar Max. 10 bar

Test Selection	Accessory	Standard Range	Max. Range
Force	-	3000 N	5000 N
Compression Strength	-	153 N/cm ²	255 N/cm ²
Splitting Strength	-	120 N/cm ²	200 N/cm ²
Twin-Transverse Shear Strength	PQS/M	76.4 N/cm ²	127 N/cm ²
Core Transverse Strength	PBV/M	6006 N/cm ²	10009 N/cm ²
Core Tensile Strength	PZV/M	598 N/cm ²	996 N/cm ²
High Compression Strength	PHD/M	917 N/cm ²	1528 N/cm ²

3 Short Description & Specifications

Component	PVF-C
PLC (Programmable Logic Control)	Siemens CPU 313C
Communication Processor	CP 340 RS232C
Power Supply Unit	Power supply unit PSU100S AC 120/230V; 24V DC/2.5A
Display	Siemens Simatic HMI KTP400 Comfort
Path Measurement	Transmetra path sensor
Length Measurement Amplifier	Path sensor amplifier Phönix
Load Measurement	Force absorber HBM 5kN
Force Measurement Amplifier	DAD 141.1
Pneumatic Measurement	Festo pneumatic cylinder
Pneumatic Control	Festo pneumatic valve

3.5 Accessories

3.5.1 Transverse Strength Attachment (Model PBV/M)

This accessory is mounted on the Minilab, Model PVF-C, and is used to determine the transverse strength of standard core sand transverse specimens. With the PBV/M Base Plate mounted on the Minilab, a transverse specimen is placed on the two Base Bolts and force is applied at the center, initiating a bending force.



Specifications	Transverse Strength Attachment
Length	ca. 190 mm (7.48 in.)
Width	ca. 50 mm (1.97 in.)
Height	ca. 65 mm (2.56 in.)
Weight	ca. 0.58 kg (1.28 lb.)

3 Short Description & Specifications

3.5.2 Twin-Transverse Shear Strength Attachment (Model PQS/M)

This accessory is mounted on the Minilab, Model PVF-C, and is used to determine the shear strength of clay bonded molding sands. With the PQS/M Base Plate mounted on the Minilab, a standard sand specimen of 50 mm x 50 mm is placed on the two Support Plates with its radial surface against the curved edge of each plate. The Shear Unit comes down with the Piston and instigates a shear force at two locations along the vertical plane.



Specifications	Twin-Transverse Shear Strength Attachment
Length	ca. 100 mm (3.93 in.)
Width	ca. 55 mm (2.17 in.)
Height	ca. 52 mm (2.05 in.)
Weight	ca. 0.98 kg (2.16 lb.)

3.5.3 Screening Device for Preparation Sample (Model 42100A)

This accessory is not mounted on the Minilab. It is used along with the Test Specimen Tube, Model 42100A, and Minilab Pedestal to develop standard test specimens. Sand is poured through the 42100A-M screen and funnel, which sifts and pours the sand into the test specimen tube for Minilab test preparation.



Specifications	Tube Filler Accessory
Length	ca. 8.2" (210 mm.)
Width	ca. 8.25" (210 mm)
Height	ca. 14" (356 mm)
Weight	ca. 2.6 lbs. (1.2 kg)

3.5.4 Tensile Strength Device (Model PZV/M)

This accessory is mounted on the Minilab, Model PVF-C, and is used to determine the tensile strength of chemically bonded core sand molding foundry sand specimens. With the PZV/M mounted on the Minilab, a standard metric dog bone tensile specimen is placed vertically between the two clamps and force is applied at the top, initiating a tensile force.



Specifications	Transverse Strength Attachment
Length	ca. 135 mm (5.31 in.)
Width	ca. 85 mm (3.35 in.)
Height	ca. 160 mm (6.30 in.)
Weight	ca. 2.40 kg (5.29 lb.)

3 Short Description & Specifications

3.5.5 High Pressure Measuring Device (Model PHD/M)

This accessory is mounted on the Minilab, Model PVF-C, and is used to determine high-pressure compression strength of foundry sands. With the PHD/M base plate mounted on the Minilab, a standard sand specimen of 50 mm x 50 mm is placed on the Minilab pedestal and placed below the squeeze pinch. The PHD/M roller is pressed down by the minilab piston and results in a compression force with a force factor of 6.



Specifications	Transverse Strength Attachment
Length	ca. 245 mm (9.65 in.)
Width	ca. 120 mm (4.72 in.)
Height	ca. 168 mm (6.61 in.)
Weight	ca. 15.6 kg (34.4 lb.)

4 Unpacking and Installation

4.1 Unpacking

NOTICE

Your new laboratory equipment has been closely inspected before being shipped to your plant. However, damage can occur en route, so it is wise to inspect all equipment on arrival. Notify both the carrier and Simpson of any damage at once. Damage should be noted on the shipper's receipt before signing for receipt of the shipment.

The Minilab, Model PVF-C, is shipped in one piece with detached cables, fittings, and accessories. It is intended to be used as received; the only additional assembly required is ensuring cable connections and fitting connections. No lifting equipment is required for handling. The Model PVF-C equipment weighs approximately 56 kg (123 lbs.). Due to its bulky dimensions and tight-fitting shipping crate, it is recommended that two people remove the equipment from the crate. Whenever positioning or relocating this instrument, two people should be utilized. The approximate instrument dimensions are 830 mm (32.6 in.) x 400 mm (15.7 in.) x 250 mm (9.8 in.). Its shipping weight (in a crate) is approximately 60.5 kg (133 lbs.).



ONLY authorized personnel may unload and install this equipment. Two people may be required to unpack this instrument due to the bulky dimensions and tight-fitting packing crate.

4 Unpacking and Installation

1. Remove any loose accessories/parts within the shipping crate and place them in a location away from any packaging material to ensure that these items are not misplaced.
2. Carefully remove the testing equipment from the packaging crate and place it on stable bench.
3. Once removed from the crate, proceed by taking off any protective wrap and packaging from the testing equipment and included accessories.
4. The packaging remains the property of the customer and may be used for returning the apparatus if repair is ever required.

4.2 Components

The following items are included with the Minilab:

- Operating Instructions Manual
- Connecting Cable – PC 9 Pole
- Power Cable 230V
- Specimen Tube 120mm
- Ramming Pedestal Type F
- Sand Chute Collection Base
- Transverse Strength Attachment (Model PBV/M)
- Twin-Transverse Shear Strength Attachment (Model PQS/M)

The following are available as accessories:

- Screening Device for Preparation Sample (Model PES)
- Tensile Strength Device (Model PZV/M)
- High Pressure Measuring Device (Model PHD/M)
- 50 mm Round Calibration Insert
- Test Spring with Load-Path Diagram

If any of the above components are missing (excluding accessories), contact your local Simpson office. See Figures 8.1 – 8.3 for apparatus layout and components.

NOTICE *Do not store the device in the open and unprotected from atmospheric conditions. If this instruction is not followed, claims under guarantee will no longer be considered.*

4.3 Installation

The installation of the apparatus is the responsibility of the client to include procuring and preparing the material required for this purpose.

The Minilab should be placed on a stable, non-slippery surface, free of vibrations. This surface should also have sufficient load-bearing capacity to support the weight of the Minilab. It is also recommended that the machine be placed in a level condition to yield more accurate test results.

The Minilab would be operated by one person at a time. This equipment is for use in a foundry sand laboratory. It is recommended that the equipment be placed in an ergonomically efficient position, with display at eye level, to facilitate the placement and measurement of test specimens & equipment.

4.4 Electrical and Pneumatic Power Connection

Electrical requirements: 230 Volts, 50 Hz

Pneumatic requirements: compressed air, filtered and regulated between 5 and 10 bars (72 psi and 145 psi).

This equipment includes a connecting plug and integrated fuse 230V AC / 50 Hz. The connection to power supply is by means of this supplied power cable.



Before connecting the equipment, an approved pneumatic safety Lock-Out air valve must be installed in the supply air- line. This item is not supplied with the equipment and is the responsibility of the customer to provide and install.



Verify that the voltage marked on the serial number nameplate is the same as the electrical outlet to be used for the machine. The outlet must be properly grounded! Failure to follow safety procedures could result in severe injury.



A pressure regulator/filter and fittings required to connect the Minilab to the regulator/filter have been included with the equipment package and will need to be attached to the machine as shown in Figure 8.2. Supplying a pneumatic hose from the air supply to Minilab fittings is the responsibility of the customer.

NOTICE

The compressed air should be free of dirt, debris, and condensate. Debris and condensate will cause damage to the equipment.

4.5 Connecting Power and Set-Up

1. Verify the voltage on the specification plate located on the back of the Minilab. Connect the power cable supplied with the equipment into the power plug receptacle located on the back of the machine (Figure 8.2, Item 6).



Some environments may require an electrical plug that is not supplied with the power cord in order to properly conform to the specific electrical outlet. These special electrical plugs will need to be purchased separately by the customer.

2. Verify the proper voltage of the electrical outlet before plugging the power cord into the outlet. Connect power cord to the AC electrical outlet that is free of disturbances/fluctuation and is properly grounded.

NOTICE

It is highly recommended that a voltage stabilizer/filter (line conditioner) is installed between the electrical outlet and the inlet of the Minilab. This device will help to ensure the proper performance of the equipment.

3. Connect the Minilab to the factory pneumatic supply line, connection located on the rear of device.
4. Turn on the air supply. Using the supplied air regulator/filter/lubricator adjust the air pressure to 5 bar (70-75 PSI). Refer to the manufacturer's manual for the regulator/filter for instructions on regulating air pressure.

4 Unpacking and Installation

4.6 Airborne Noise Emission

There is no motor or other noise emitted by this machinery other than the click of a solenoid valve being operated. As such, the equivalent continuous A-weighted sound pressure level at the workstation does not exceed 70dB(A).

5 Commissioning

5.1 Adjustments

After the Minilab has been installed (See Section 4, “Unpacking and Installation”) the following steps should be executed:

5.1.1 Compressed Air Pressure

1. Carefully open the Shut-off Ball Valve (Figure 8.2, Item 4) on the rear of the device.
2. The operating pressure for the Minilab should be set to 4.5 bar with the Pressure Regulator (Figure 8.2, Item 3). This is done by first pulling the rotary knob on the Pressure Regulator outwards and then adjusting, as necessary.
3. As the Piston (Figure 8.1, Item 3) descends, read the air pressure setting on the Pressure Gauge (Figure 8.4, Item 1).



If the pressure on the Pressure Regulator is adjusted without the squeezing Piston being moved, this can lead to a false pressure display.

4. When necessary, the pressure should be reset during operation of the Minilab (see Section 6 “Operating Instructions”).
5. Push the pressure regulator rotary knob inwards to lock and prevent unintentional pressure adjustment.

5 Commissioning

5.1.2 Power

Set the Main Switch (Figure 8.3, Item 1) to "ON". This turns on the power for the Minilab control system, and the display begins to illuminate. After approximately 30 seconds the opening screen is displayed.

During lengthy interruptions, e.g., overnight or on weekends, the Minilab can be switched off with the Main Switch.

5.2 Operating Component and Functions

5.2.1 Operator Panel (OP)

During testing, the measurement values are shown on the Operator Panel (Figure 8.1, Item 6) display.

The number keys are used to enter changes for factors which must be altered. Navigation is conducted by the directional cursor keys.

The "Enter" key is used to confirm the entered values.

The "Esc" key is used to browse to a previous menu level by double clicking.

The function keys (F1, etc.) will be on screen and are used to access sub-menus or to start a function.

If a "<" or ">" symbol is displayed, this indicates that a further page is available. These can be accessed with the cursor key.

An outline of the complete menu arrangement is shown in Figures 6.1 & 6.2.

The "Shift" key is used to access the second function on twin-function keys.

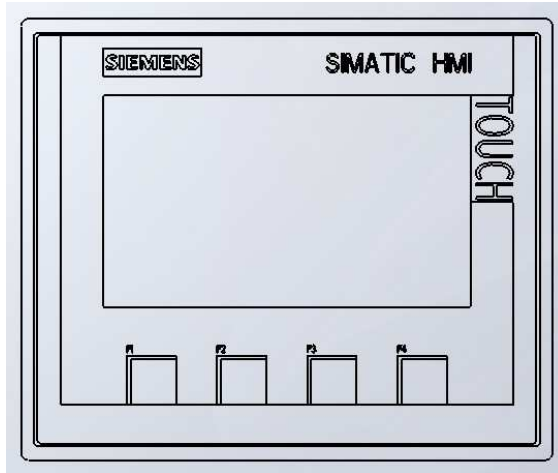

Figure 5.1

5.3 Connecting External Devices

5.3.1 Personal Computer (PC)

A PC may be connected to the Minilab with the supplied serial cable for downloading and managing test data. This is done by connecting the serial cable to the COM port at the Minilab rear (Figure 8.2, Item 5).

Several programs are available for data collection. One such program is the terminal program, Hyper Terminal (integrated in Windows operating system).

To start this program, give the test a name, e.g., Minilab, and select the COM port on the PC to which the Minilab serial cable is connected.

Set the following parameters in the configuration:

Bits per second:	9600
Data bits:	8
Parity:	None
Stop bits:	1
Protocol:	None

After the connection to the PC is established, data from the Minilab can be recorded. It is recommended that the data be stored as a text file to permit further processing with Microsoft Excel or similar data management programs.

If using Excel for data management, the following settings are recommended in the text wizard.

1. Select “Delimited.”
2. Select “Space” as the delimiter.
3. Indicate whether a column will be imported.

5.3.2 Printer

If you wish to send the data directly to a printer rather than store it on a PC, you can connect a printer directly to the Minilab by means of an RS-232 parallel adapter. Configure the adapter the same as you would for a PC (see previous section). A suitable adapter is available as an accessory.

The interface is optimized for an HP Deskjet printer; however, other types of printers may be used.

6 Operating Instructions



For more information on how to use and care for your Simpson Analytics equipment and accessories visit our Simpson channel on YouTube and search our library of videos. Subscribe to our channel to keep updated on new releases.

6.1 Menu Outline

6.1.1 Measurements

The “Measurements” menu is accessed by clicking the F1 button. This menu displays buttons for the 10 tests available with the PVF-C Minilab: Compactability, Test sample, Compressive strength, Splitting strength, Shear strength, Transverse strength, Tensile strength, High pressure, Permeability, and Wet tensile strength. The desired test commences once the corresponding test is selected from this menu. See Section 6.2 for operation instructions.



6.1.2 Options

The “Options” Menu is accessed by clicking the F2 button. This menu allows for adjustment in correction factors, calibration, printing, scale range, force test sample, date + time, language, authorization, logging on, and logging off. The desired setting may be adjusted by clicking on the corresponding button.

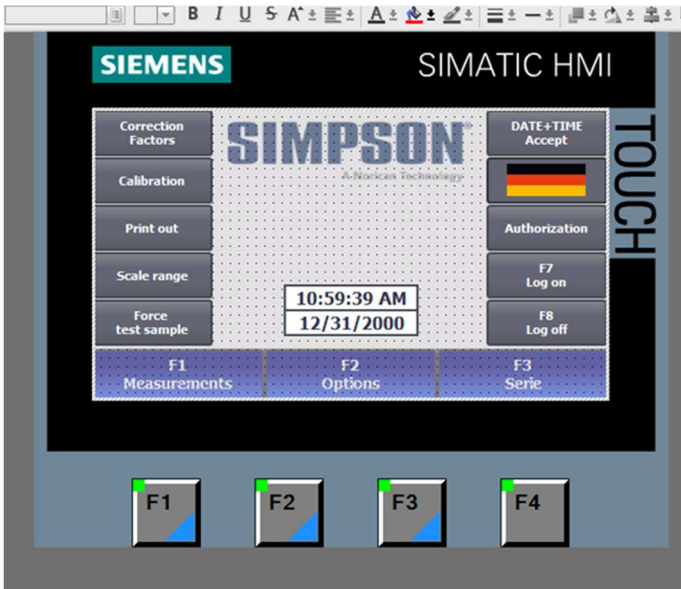

6.1.2.1 Correction Factors

The “Correction Factors” menu under options is available to make cosmetic test result changes if desired. This menu is only utilized by customers in extraordinary circumstances (e.g., if a transverse specimen being used is a different thickness than the standard specimen). The standard value for all correction factors is 1. Deviating from the standard is at the discretion of the customer and will result in displayed results that do not accurately represent the force exerted during testing.

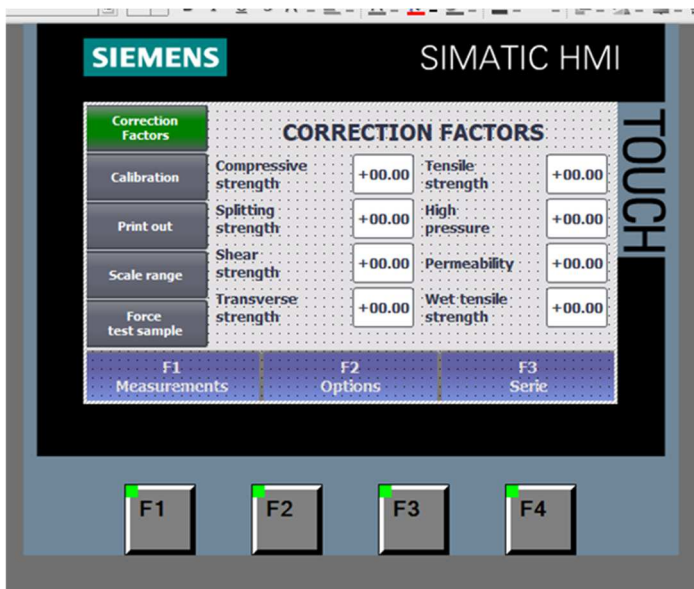

6.1.2.2 Calibration

The technical measurement settings may be found on the menu, "Calibration." "Way" indicates the piston displacement, and "Force" indicates the force exerted by the piston on the sample during measurement. In the "Max way" display box, the maximum displacement for piston movement during a measurement should be entered (see Section 7.3).



6.1.2.3 Print Out

In the menu, "Print," the user can switch between "Manual" and "Automatic" by clicking the "Print-out mode" button.

With "AUTO," the result of each measurement is sent to the serial interface.

With "Manual," the complete data record can be printed at any time. A maximum of 100 data records are stored. The memory works on the basis of the "FIFO" principle (First-in, First-out). When the 101st. data record is ready, the first record is deleted, and all others move down one memory place. The number of data records is displayed under "Current." If part of the data record must be printed on a separate sheet, the Minilab must be switched off with the Main Switch (Figure 8.3, Item 1) and then switched on again.

All data records can be transferred to a PC rather than printing the data if so desired. This is done by connecting a PC to the serial interface on the Minilab instead of a printer. The connection can be established with the Windows standard software "Hyper Terminal." The data transmitted by the Minilab can only be stored as a text file. The settings on the Minilab for the transmission of data are the same as for a printer (see Section 5.3.1 & 5.3.2).



6.1.2.4 Scale Range

The measuring range is set with this menu. Because a change in the measuring range also requires an alteration of the measuring amplifier, this entry is protected by password and only accessible by the technical service of Simpson .

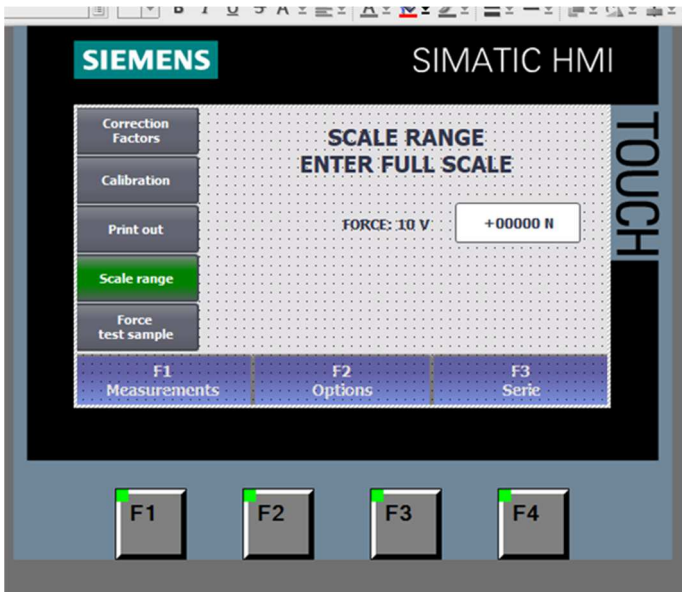

6.1.2.5 Force Test Sample

The Force Test sample is set to 1963N by default. This corresponds to a pressure of 100 N/cm² on the test specimen.

The Force Test sample can be changed with customer username “C” and password 3472.



The change of the Force Test sample has a direct influence on the subsequent strength measurement: the higher the force, the higher the compressive strength. Before changing the force, the influence of the compactability should also be examined (with the same Force Test sample).



6.1.2.6 Date + Time.

By clicking the “Date + Time” button, this menu permits the adaption of the date and time with the number block on the OP.

6.1.2.7 Language

There are five languages readily available for use with the Minilab by clicking the flag button. On the language menu, the following languages may be selected: German, English, Italian, French, and Portuguese.

6.1.2.8 Authorization

The “Authorization” menu can be accessed after the password has been entered and confirmed with "Enter" and “OK.” The window, "Assign Password," is displayed for the entry of the passwords attaining to the individual levels. These menus are only accessible by the technical service of Simpson .

6.1.2.9 Log On

By clicking the “Log on” button, the user may enter a username and password (see section 6.1.2.5) to make changes to the options. The permission granted through logging on remains only for 5 minutes and will automatically log out at this time.

6.1.2.10 Log Off

After logging in to make changes and take measurements, it is recommended that the user logs out and leaves the password level. The permission to make changes remains active for 5 minutes without a logout. Without logging out, there is a possibility of important settings being changed. Press the "Enter" button in order to log out.

6.1.3 Measurement Series

In addition to the use of letters, there are 99 measurement identification numbers available (01-99) for Minilab operation. Measurement identification allows operators to differentiate between users, sand types, or any other differentiating factor desired.

For example, if more than one user operates the Minilab, each person can be issued a number with the Measurement Range Description. This number may later be seen in the protocol and identifies the operator and their set of measurements.

Also, for different sand systems, each system could be issued a number. Therefore, sand types can later be differentiated for specific measurements.



6.2 Operation

After the commissioning has been completed in accordance with Section 5, testing may commence.



Before starting any measurement or testing specimen manufacture, be sure to close the lower front Protection Doors (Figure 8.1, Item 5). The doors are to keep the operator safe from moving parts and debris and are equipped with safety switches that will not allow machine operation while Protection Doors are open.

6.2.1 Test Specimen Manufacture

1. Place the Specimen Tube (Figure 8.1, Item 12) on top of the Pedestal (Figure 8.1, Item 14). The small edge of the tube must be facing upward.
2. Fill the Specimen Tube with a quantity of sand necessary that will result in a compacted specimen with height 50 mm.
3. Place the prepared Specimen Tube and Pedestal in their position under the Piston (Figure 8.1, Item 3) on the PVF-C and close the Protection Doors (Figure 8.1, Item 5) (see Figure 6.2.1).

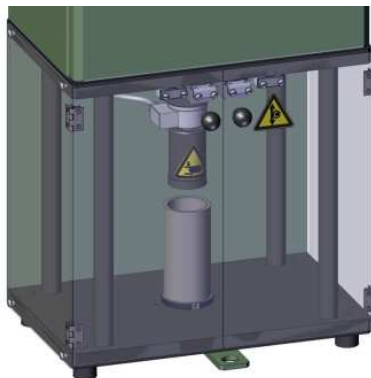
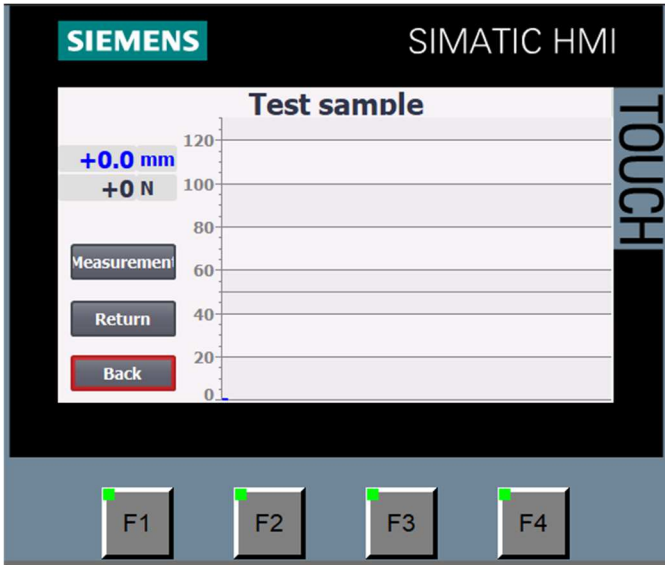

Figure 6.2.1

4. Select menu, "Test sample," on the Operator Panel (Figure 8.1, Item 6) and press the "Measurement" Button (Figure 8.1, Item 1) on the enclosure door to begin manufacture.



The Piston extends downward and compacts the sand with a pressure of 100 N/cm² (with the standard 1963 N. Force settings may be adjusted in accordance with Section 6.1.6) The height of the test specimen (in mm) is shown on the display. It should be 50mm ± 0.3mm. During the compacting process, the current force is also shown on the display.

5. After completion of the measurement, remove the Specimen Tube and eject the sand specimen with the removal pin.
6. Repeat steps 1 – 5 to manufacture further test specimens if needed.



A test specimen manufactured by squeezing does not possess the

same compressive strength as one manufactured by ramming.

6.2.2 Compactability Measurement

1. With Pedestal (Figure 8.1, Item 14) underneath, fill the Specimen Tube (Figure 8.1, Item 12) using a sieve, and level off the excess molding sand. The small edge of the tube must be facing upward.
2. Place the prepared Specimen Tube and Pedestal in their position under the Piston (Figure 8.1, Item 3) on the PVF-C and close the Protection Doors (Figure 8.1, Item 5) (see Figure 6.2.1).
3. Select menu, "Compactability," on the Operator Panel (Figure 8.1, Item 6) and press the "Measurement" Button (Figure 8.1, Item 1) on the enclosure door to begin testing.

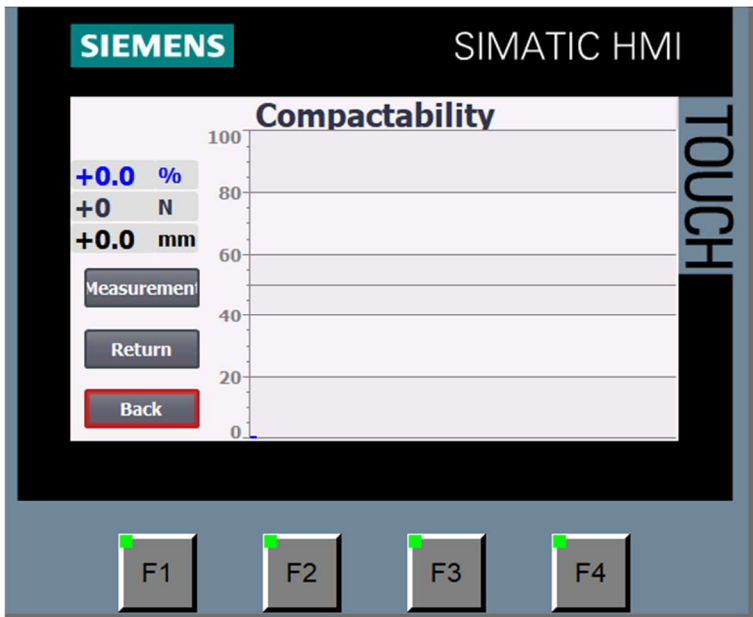



The Piston extends downward and compacts the sand with a pressure of 100 N/cm² (with the standard 1963 N. Force settings may be adjusted in accordance with Section 6.1.6). The compatibility is shown as a percentage on the display. During the compacting process, the current force is also shown on the display.

4. After completion of the measurement, remove the Specimen Tube and eject the sand specimen with the removal pin.

6.2.3 Compression Strength Measurement

1. Prepare a test specimen as specified in Section 6.2.1.
2. Place the Sand Chute (Figure 8.1, Item 13) over the top of the Pedestal (Figure 8.1, Item 14), secure with set screws on both sides, and place the Pedestal in its position, centered on the Minilab Base Plate (Figure 8.1, Item 9).



Use of the Sand Chute in the previous step is not absolutely necessary, but it simplifies cleaning after the measurement.

3. Center the flat surface of the prepared test specimen on the Pedestal and close the Protection Doors (Figure 8.1, Item 5) (see Figure 6.2.2).

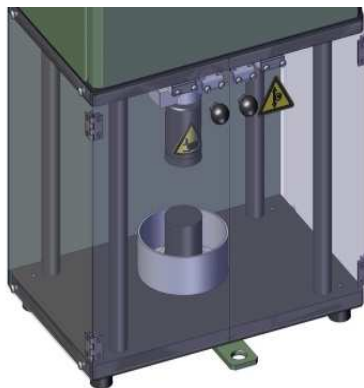

Figure 6.2.2

4. Select menu, "Compressive Strength," on the Operator Panel (Figure 8.1, Item 6) and press the "Measurement" Button (Figure 8.1, Item 1) on the enclosure door to begin testing.



The Piston extends downwards and exerts a force on the test specimen until it breaks. The maximum breaking force required relates to the compressive strength in N/cm^2 and is shown on the display.

5. After completion of the measurement, remove the Pedestal and Sand Chute and clean off any sand deposits.

6.2.4 Splitting Strength Measurement

1. Prepare a test specimen as specified in Section 6.2.1.
2. Place the Sand Chute (Figure 8.1, Item 13) over the top of the Pedestal (Figure 8.1, Item 14), secure with set screws on both sides, and place the Pedestal in its position, centered on the Minilab Base Plate (Figure 8.1, Item 9).



Use of the Sand Chute in the previous step is not absolutely necessary, but it simplifies cleaning after the measurement.

3. Center the radial surface of the prepared test specimen on the Pedestal and close the Protection Doors (Figure 8.1, Item 5). (There are grooved radial surfaces on the Sand Chute to aid the specimen placement on the Pedestal.)

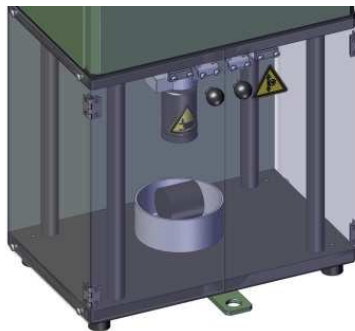
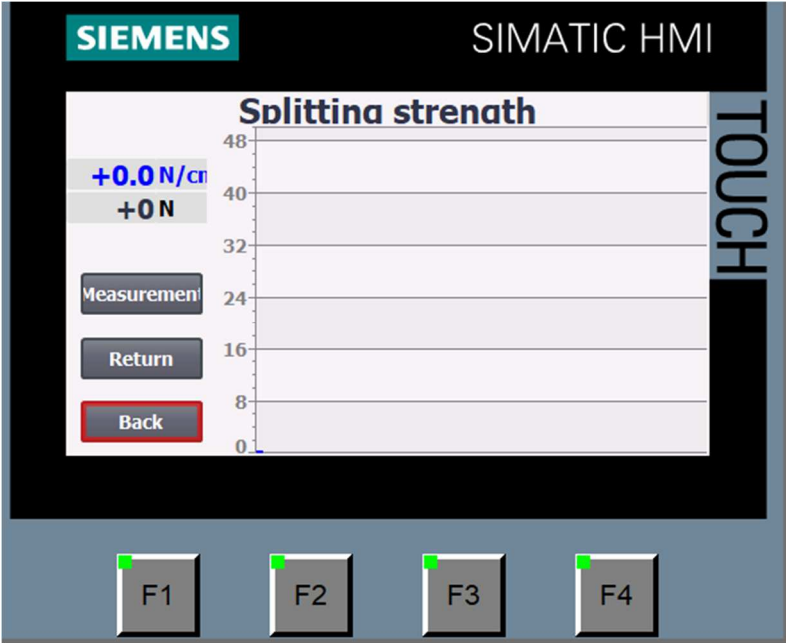

Figure 6.2.3

4. Select menu, "Splitting Strength," on the Operator Panel (Figure 8.1, Item 6) and press the "Measurement" Button (Figure 8.1, Item 6) on the enclosure door to begin testing.



The Piston (Figure 8.1, Item 3) extends downward and exerts a force on the test specimen until it breaks. The maximum breaking force required relates to the splitting strength in N/cm^2 and is shown on the display.

5. After completion of the measurement, remove the Pedestal and Sand Chute and clean off any sand deposits.

6.2.5 Twin-Transverse Shear Strength Measurement (PQS/M)

Prepare a test specimen as specified in Section 6.2.1.

1. Remove the Compression Insert (Figure 8.1, Item 4) (if applicable) from the Piston (Figure 8.1, Item 3) (see Figure 6.2.4) and align the two pins of the Twin-Transverse Shear Attachment Shear Unit (Figure 8.1, Item 11) in its place (see Figure 6.2.5).

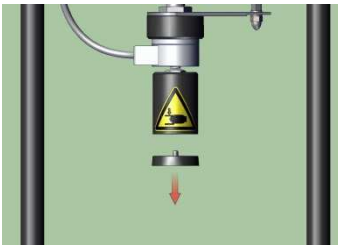

Figure 6.2.4

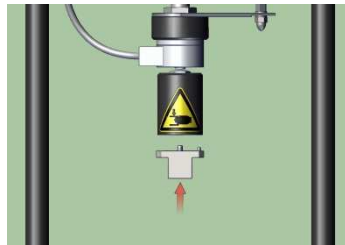

Figure 6.2.5

2. Align the Twin-Transverse Shear Attachment Base on the Minilab Base Plate (Figure 8.1, Item 9), ensuring that attachment cylinder pins are mounted in the corresponding holes on the machine base (see Figure 6.2.6).

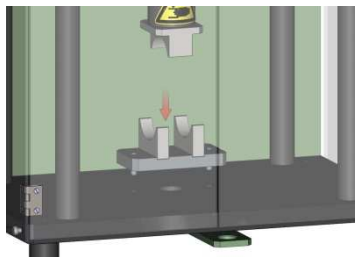

Figure 6.2.6

3. Center the radial surface of the prepared test specimen on the curved edges of the Twin-Transverse Shear Attachment Base and close the Protection Doors (Figure 8.1, Item 5) (see Figure 6.2.7).

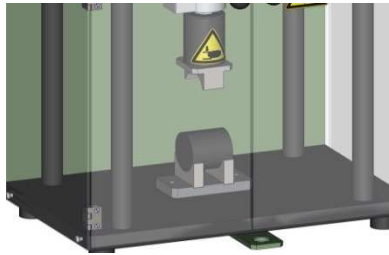

Figure 6.2.7

4. Select menu, "Shear Strength," on the Operator Panel (Figure 8.1, Item 6) and press the "Measurement" Button (Figure 8.1, Item 1) on the enclosure door to begin testing.



The Piston extends downwards and exerts a force on the test specimen until it breaks. The maximum breaking force required relates to the shear strength in N/cm^2 and is shown on the display.

5. After completion of the measurement, remove the Twin-Transverse Shear Attachment Base and Shear Unit, and clean off any sand deposits.

6.2.6 Transverse Strength Measurement (PBV/M)

1. Prepare a core transverse test specimen.
2. Remove the Compression Insert (Figure 8.1, Item 4) (if applicable) from the Piston (Figure 8.1, Item 3) (see Figure 6.2.4) and align the two pins of the Transverse Strength Attachment Cutter (Figure 8.1, Item 10) in its place (see Figure 6.2.8).



Figure 6.2.8

3. Align the Transverse Strength Attachment Base on the Minilab Base Plate (Figure 8.1, Item 4), ensuring that attachment cylinder pins are mounted in the corresponding holes on the machine base (see Figure 6.2.9).



Figure 6.2.9

- Center the wide surface of the prepared test specimen on the Transverse Strength Attachment Base Bolts and close the Protection Doors (Figure 8.1, Item 5) (see Figure 6.2.10).

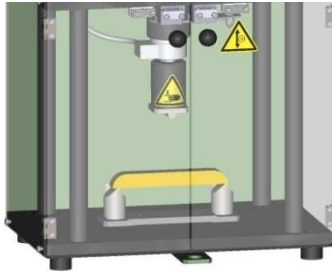
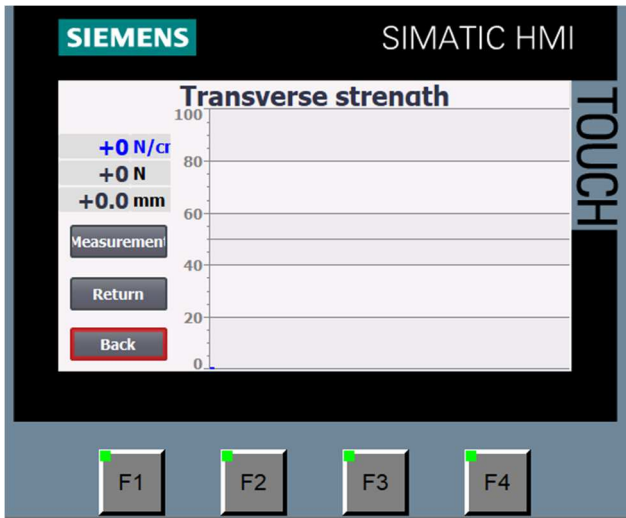

Figure 6.2.10.

- Select menu, "Transverse Strength," on the Operator Panel (Figure 8.1, Item 4) and press the "Measurement" Button (Figure 8.1, Item 5) on the enclosure door to begin testing.





The Piston extends downward and exerts a force on the test specimen until it breaks. The maximum breaking force required relates to the bending strength in N/cm^2 and is shown on the display. In addition, the distance (in mm) the specimen travels until it breaks is displayed (elasticity).

6. After completion of the measurement, remove the Twin Transverse Strength Attachment Base and Cutter, and clean off any sand deposits.

6.2.7 Tensile Strength Measurement (PZV/M)

1. Remove the Compression Insert (Figure 8.1, Item 4) (if applicable) from the Piston (Figure 8.1, Item 3) (see Figure 6.2.4).
2. Align the Tensile Strength Attachment Base on the Minilab Base Plate (Figure 8.1, Item 4), ensuring that attachment cylinder pins are mounted in the corresponding holes on the machine base (see Figure 6.2.11).

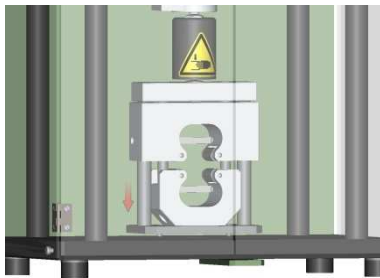

Figure 6.2.11.

3. Place the prepared dog bone test specimen in the Tension Device and close the Protection Doors (Figure 8.1, Item 5) (see Figure 6.2.12).

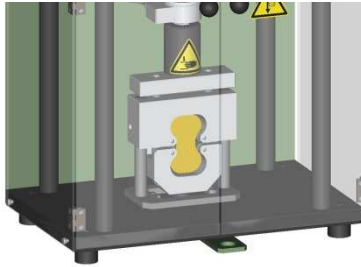
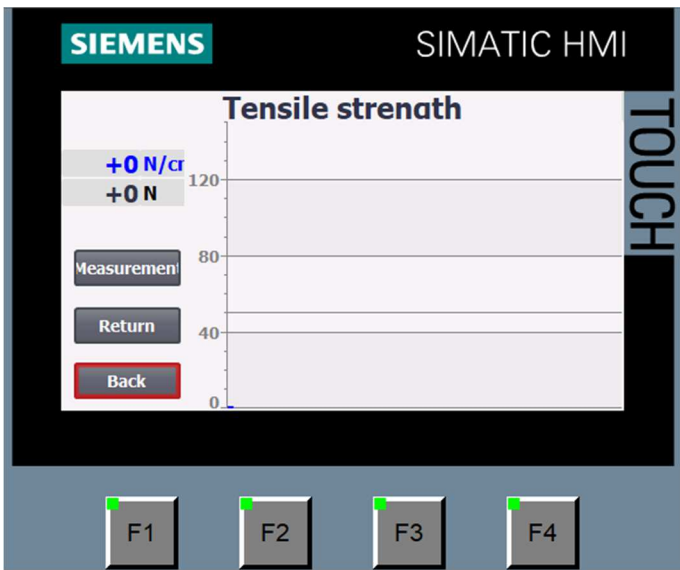

Figure 6.2.12.

4. Select menu, "Tensile Strength," on the Operator Panel (Figure 8.1, Item 6) and press the "Measurement" Button (Figure 8.1, Item 1) on the enclosure door to begin testing.





The Piston extends downward and exerts a force on the tension device. This converts the force into a tensile force and pulls the test specimen until it breaks. The maximum force required relates to the tensile strength in N/cm^2 and is shown on the display.

5. After completion of the measurement, remove the tension device and clean off any sand deposits.

6.2.8 High Pressure Measurement (PHD/M)

1. Remove the Compression Insert (Figure 8.1, Item 4) (if applicable) from the Piston (Figure 8.1, Item 3) (see Figure 6.2.4).
2. Align the High-Pressure Measurement Attachment Base on the Minilab Base Plate (Figure 8.1, Item 4), ensuring that attachment cylinder pins are mounted in the corresponding holes on the machine base (see Figure 6.2.13).

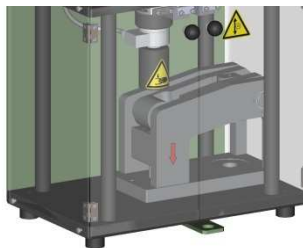

Figure 6.2.13.

3. Place the Minilab Pedestal in the High-Pressure Measuring Device base (see Figure 6.2.14).

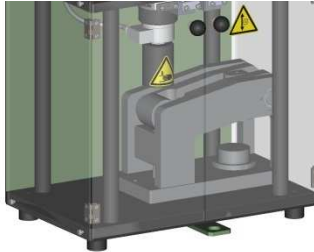

Figure 6.2.14

4. Center the flat surface of the prepared test specimen on the Pedestal and close the Protection Doors (Figure 8.1, Item 5) (see Figure 6.2.15).

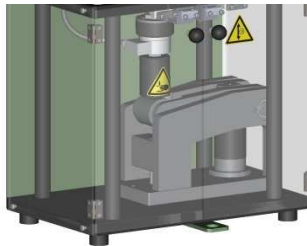
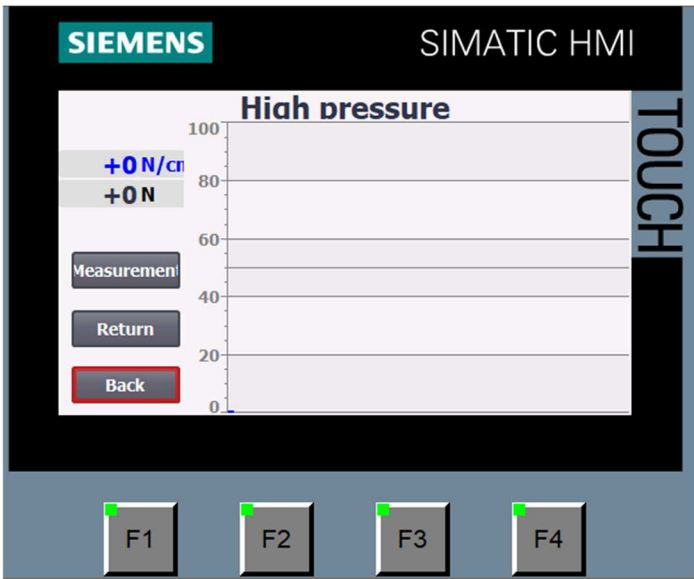

Figure 6.2.15

5. Navigate to the high-pressure test menu, and select the menu, "High pressure," on the Operator Panel (Figure 8.1, Item 4). Press the "Measurement" Button (Figure 8.1, Item 5) on the enclosure door to begin testing.



The Piston extends downward and exerts a force on the high-pressure measuring device. This amplifies the force by a factor of 6 and presses the test specimen until it breaks. The maximum force required relates to the compressive strength in N/cm^2 and is shown on the display.

6. After completion of the measurement, clean the High-Pressure Measuring Device from sand deposits.

6.2.9 Wet Tensile Strength Measurement

1. Connect the Wet Tensile Strength Testing Apparatus (Model PNZ), equipped with the Analog Output PNZ, to the interface

connection on the rear of the Minilab labelled, “Wet Tensile Strength” (Figure 8.2, Item 2).

2. Select menu, “Wet Tensile Strength,” on the Operator Panel (Figure 8.1, Item 6). The measurement results will automatically be displayed on the Minilab.
3. Complete the wet tensile strength test with supplementary equipment according to that equipment’s instructions & standards.

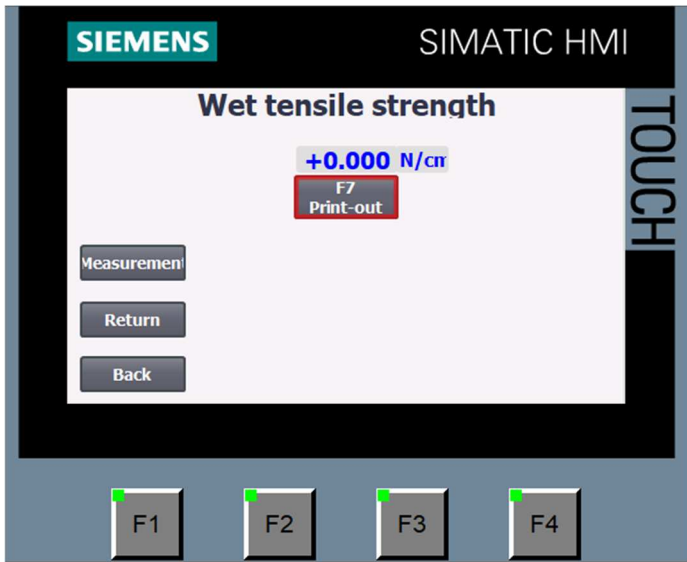

7 Maintenance and Calibration



For more information on how to use and care for your Simpson Analytics equipment and accessories visit our Simpson channel on YouTube and search our library of videos. Subscribe to our channel to keep updated on new releases.

Despite its robust construction, the Minilab, Model PVF-C, is a precise mechanical measurement device and needs appropriate care.



*Before performing any maintenance or calibration, ensure that the power is switched OFF at the Main Switch. Always follow **Lockout and Tagout** procedures.*

7.1 Daily Maintenance

- Remove and clean any sand/dirt deposits in the working area with a brush and wipe the operating elements clean with a soft cloth.



As an added measure of safety and equipment care, ensure that all doors are closed after maintenance.



The CPU does not have a backup battery. All data is stored in the Micro Memory Card. The CPU cannot run without it. Removal of this card will prevent the equipment from operating.

NOTICE

Incorrect operation of the selector switch can result in CPU content being deleted. In this case, the program and all Minilab data will be lost; Minilab operation will be halted until the program can be reloaded with corresponding Siemens software. Further literature may be found on the Siemens website.

7.2 Quarterly Maintenance (Every Three Months)

- Perform the commissioning adjustments as described in Section 5.1 to ensure proper performance of the testing equipment.

7.3 Calibration

The devices supplied by the technical service of Simpson are calibrated before delivery. Therefore, calibration during the initial commissioning is not absolutely necessary.

1. The correct function of the Minilab can be checked with the menu "Calibration."
2. Select the main screen "Options" with the function key, F2 (see Figure 6.1).
3. Select "Calibration."
4. The displacement should be indicated as -30.0mm. A difference of $\pm 0.2\text{mm}$ is allowable.
5. A force of 0N should be indicated. A difference of $\pm 100\text{N}$ is allowable because the start value is accounted for with each measurement and subtracted at the end of the measuring process.

6. The preset value is 52.0mm and must not be altered for standard test specimens.
7. Place a 50mm tall Calibration Insert with the Pedestal (Figure 8.1, Item 14) under the Piston.



Ensure that the Piston presses the Calibration Insert with a force of approximately 2000 N when the operating pressure is set to 2.5 bar. If you are not certain that the calibration insert can support this pressure, reduce the operating pressure on the Pressure Regulator (Figure 8.2, Item 3).

8. Press the "Measurement" Button (Figure 8.1, Item 1). The Piston now extends downwards against the calibration insert. A "path" of 50.0 mm (± 0.1 mm) must be indicated on the display.
9. Press the "Return" Button (Figure 8.1, Item 2). The Piston now retracts to its original position.
10. To check the force, a force measurement device is necessary (e.g., Part No. 596-061-103).
11. Reduce the operating pressure to about 1.7 bars (force of about 1360 N). Place the force measurement device with the Pedestal under the Piston and press the "Measurement" button. The force from the measurement device must be indicated on the display (± 5 N). Repeat the procedure with about 2.5 bar (Force about 2000 N).

If the tolerances for the displacement or force are exceeded, the Minilab must be calibrated again. Please contact the technical service of Simpson .

The Minilab can also be checked with the Test Spring. In this case, use a suitable spring which has known values and carry out a compressive strength measurement with the spring in place of a test specimen (see Section 6.2.3 for instructions on how to carry out this measurement).

Compare the results with the spring data. This is a simple and precise procedure for checking the correctness of a measurement.

Suitable springs for this procedure are available as accessories.

Exit the calibration menu by choosing another menu. The opening screen is now displayed, and the Minilab is ready for the first measurement.

Details for the various measurements can be found in Section 6.

8 Apparatus Layout

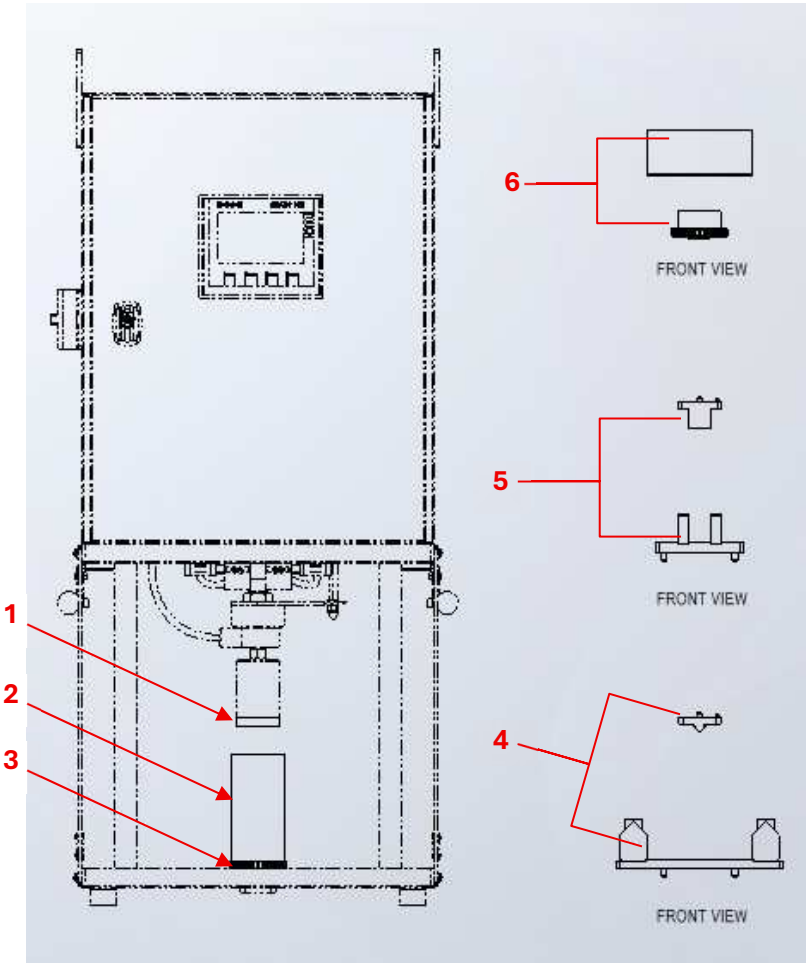

Figure 8.1: Minilab Front & Included Accessories

8 Apparatus Layout

Item	Part Number	Description
1	592-820-690	Compression Insert
2	592-805-907	Specimen Tube 120mm
3	592-820-115	Ramming Pedestal Type F
4	592-820-651	Transverse Strength Attachment
5	592-820-655	Twin-Transverse Shear Strength Attachment
6	592-820-704	Sand Chute Collection Base

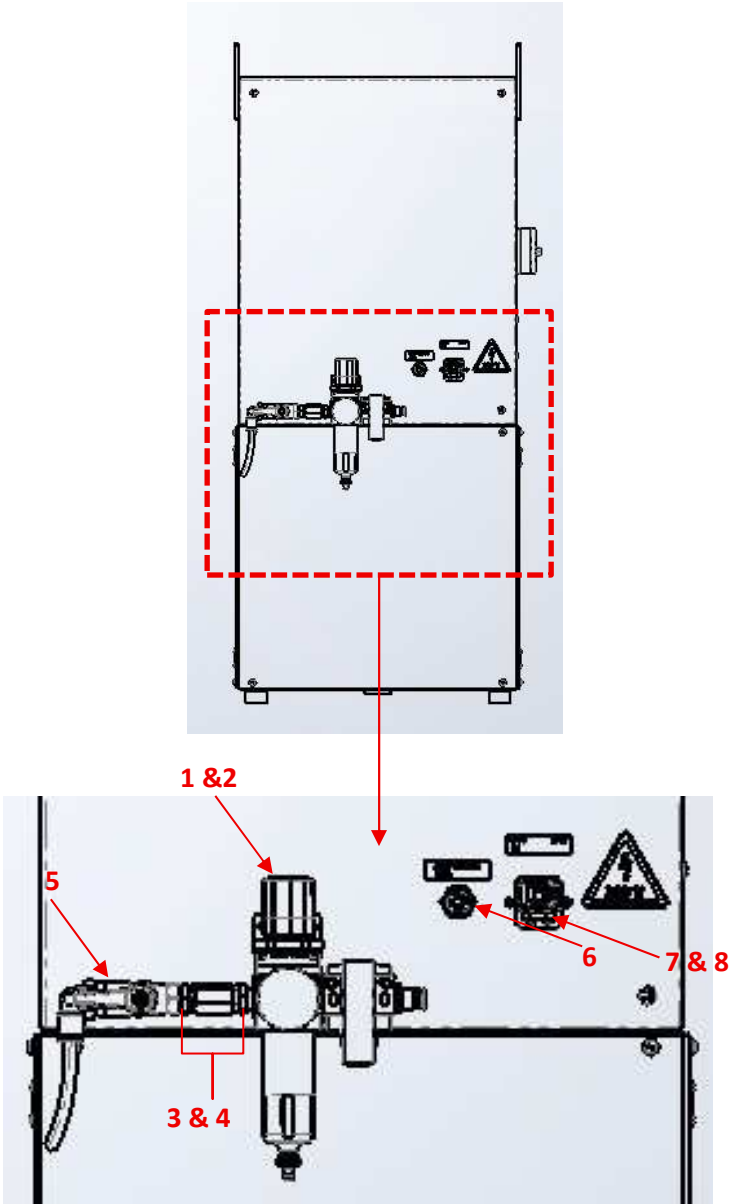

Figure 8.2: Minilab Rear

8 Apparatus Layout

Item	Part Number	Description
1	224011	Pressure Regulator
2	224012	Hex Nut for Pressure Regulator
3	596-459-258	Straight Reducer (2)
4	596-459-255	Straight Connector
5	596-405-101	Shut-off Ball Valve
6	224018	Push-on Bulkhead Connector
7	596-006-018	Power Connection Outlet
6	592-823-926	Outlet Seal Gasket

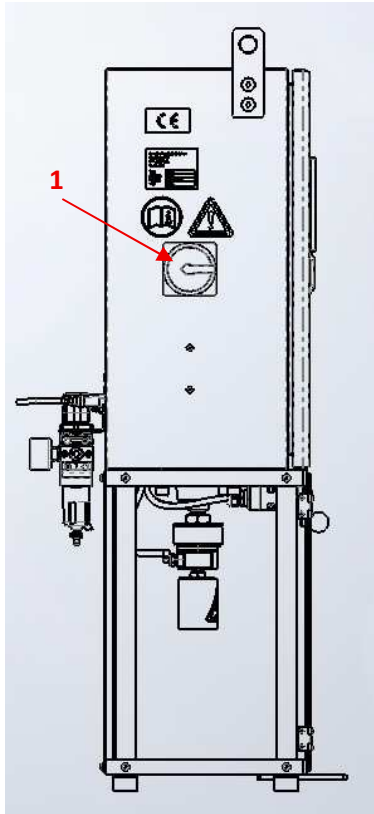

Figure 8.3:

Minilab Left Side

Item	Description
1	Main Switch

9 Parts List / Ordering Parts / Returns

9.1 Spare Parts List

Simpson maintains a large inventory of common spare parts for all current Simpson Analytics products. The following table provides part numbers for common spare parts for this device. Contact Simpson with the part number and description when ordering.

Part No.	Description
592-805-907	Specimen Tube 120mm
592-820-115	Pedestal
592-820-704	Sand Chute – Pedestal Assy.
0042100A M	Tuber Filler Assy.
592-820-651	Transverse Strength Measuring Attachment (PBV/M)
592-820-655	Twin-Transverse Shear Strength Measuring Attachment (PQS/M)
592-820-127	Calibration Insert 50mm
592-820-537	Spring Test (with Force-Path Diagram)
224002	Pneumatic Cylinder
596-036-051	Path Sensor
596-036-050	Force Sensor
592-820-690	Compression Insert
596-405-101	Shut-off Ball Valve
224011	Pressure Regulating Valve
224012	Hex Nut for Pressure Regulator
224014	Solenoid Valve
224017	Silencer - Muffler
596-440-079	Flow Regulating Valve
596-440-078	Flow Regulating Valve
596-018-039	Actuator
596-018-038	Safety Switch
592-823-926	Outlet Seal
596-006-018	Outlet Plug
596-081-005	Power Cable
596-274-002	Door Magnet
592-803-069	Tensile Strength Measuring Device (PZV/M)
592-820-705	High Pressure Measuring Device (PHD/M)

9.2 Ordering Replacement / Spare Parts

The source of replacement parts for your Simpson Analytics equipment is just as important as the make of the equipment you purchase. ALWAYS order parts for your Simpson Analytics equipment directly from Simpson . To find the Simpson office closest to you please visit us on the internet at simpsongroup.com on the “Contact” page.

Contact our sales department to obtain a quotation on replacement parts or service. Please include the equipment serial number, the description of the part, and the part number. Your Simpson sales team representative will provide you with a quote on the items with current price and delivery times. When ordering, please refer to the quote number on your order.

To arrange for calibration support or repair assistance please contact our customer service department at service@simpsongroup.com.

9.3 Return Goods Policy

Simpson strives to provide their customers with maximum follow-up support and, in order to offer the most practical flexibility, the following conditions apply to returned goods. Adherence to these procedures will ensure the most prompt and efficient service.

RETURNS WILL BE CONSIDERED IN THE FOLLOWING SITUATIONS:

- Products ordered in error by customers (subject to a restocking charge).
- Incorrect or defective products shipped to customers.
- The return of existing products for factory repair or upgrade.
- Products ordered correctly but which are unwanted or unsuitable (subject to a restocking charge).
- A Safety Data Sheet (SDS) must accompany material that is sent to Simpson for testing purposes. Simpson will NOT authorize the return of hazardous materials.

RETURN PROCEDURE:

- **The customer must obtain a Return Material Authorization Number (RMA#) from Simpson prior to returning the goods.**
- To obtain an RMA#, the customer should contact the customer service department by phone, , or e-mail to service@simpsongroup.com. The material being returned must be identified and the reason for its return clearly specified. Once approved for return, Simpson will issue the customer an RMA form to be included with the shipment and with instructions on where and how to ship the goods.
- All returned goods are to be shipped with transportation charges PREPAID, unless otherwise agreed when the RMA# is assigned. If it has been determined that return goods are to be shipped COLLECT, Simpson will specify the desired routing.
- All returned shipments will be subject to inspection upon arrival at Simpson .
- Material returned without an RMA# may be refused and returned at the customer's expense.

10 Decommissioning



*Before doing any work, review the Safety Procedures in Section 2 and **Lockout/Tagout** all the power sources to the machine and peripheral equipment.*

Failure to follow safety procedures could result in severe injury.

Use qualified personnel and follow safety procedures, applicable local policies, and regulations in decommissioning the Minilab and peripheral equipment.

Electrical Power: Disconnect the electrical power source and verify there is no power on all components being decommissioned.

Air Supply: Shut off all plant air lines supplying air to the pneumatic components and bleed the downstream air lines before dismantling.

WASTE DISPOSAL

The Machinery and Controls Consists of:

- Iron
- Aluminum
- Copper
- Plastic
- Electronic Components and Circuit Boards

Dispose of the parts in accordance with the applicable regulations.